

### FACE PLATE, BED SLIDE, COVER PLATES

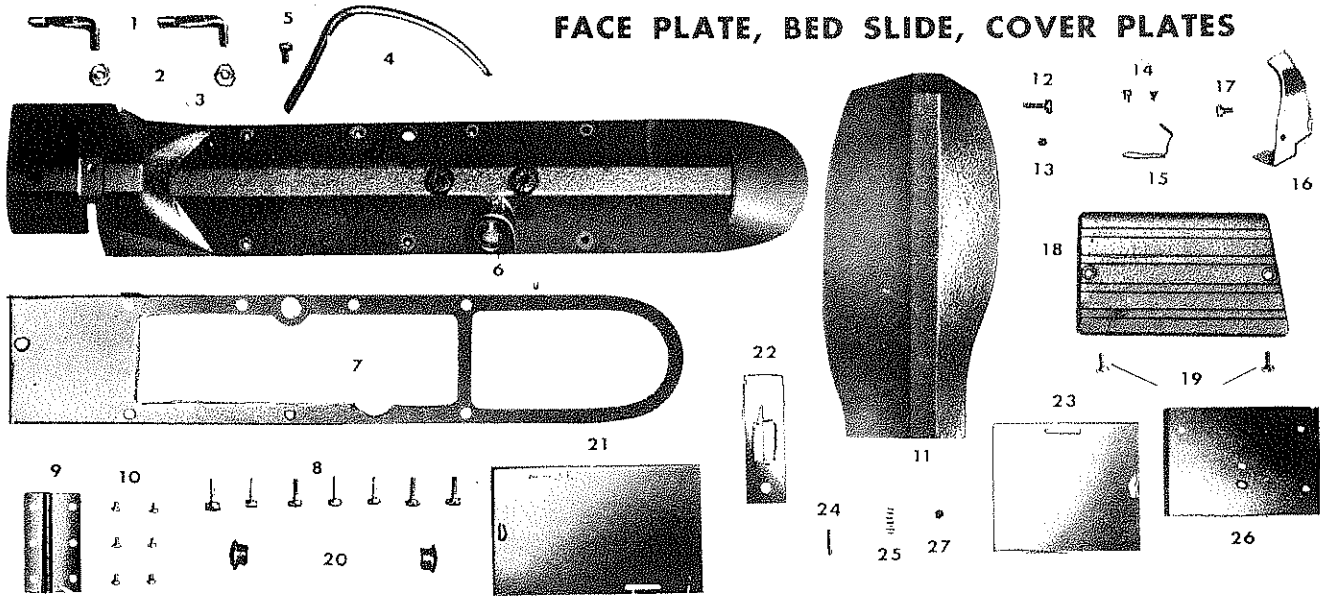

Fig.No.	Parts No.	Qty.	Name	Fig.No.	Parts No.	Qty.	Name	Fig.No.	Parts No.	Qty.	Name
1	11006	2	Top arm thread guide	15	15037	1	Face plate spring	10049	1	1	Bed slide 1"
2	13076	2	Nut for 11006	16	10551	1	Needle bar connecting link oil guard	10050	1	1	Bed slide 1 1/4"
3	15003	1	Arm top cover	17	10650	1	Screw for 10551	10051	1	1	Bed slide 1 1/2"
4	15025	1	Thread take up lever cover	18	15006	1	Arm side cover	22	1	1	Needle plate (see attached sheet)
5	6031	1	Set screw for 15025	19	8040	2	Screw for 15006	23	10060	1	Bed slide (right) 1 1/4" to 3 1/4"
6	11007	1	Oil level indicator	20	10959	2	Rubber packing on arm	10061	1	1	Bed slide 7 3/4" to 3 8"
7	15004	1	Gasket for 15003	21	10040	1	Bed slide (left) 1 1/4" to 3 3/4"	10062	1	1	Bed slide 7 1/4" to 1 2"
8	6604	7	Set screw for 15003	10041	1	Bed slide 1 8"	10063	1	1	Bed slide 5 8" to 3 4"	
9	15036	1	Hinge for face plate	10042	1	Bed slide 3 1/4" to 1 4"	10064	1	1	Bed slide 7 8" to 1"	
10	15039	6	Screw for 15036	10043	1	Bed slide 5 1/4"	10065	1	1	Bed slide 1 1/4" to 1 1 2"	
11	15035	1	Face plate	10044	1	Bed slide 3 8"	24	10667	1	1	Bed slide (back) stop
12	6604	1	Screw for 15035	10045	1	Bed slide 7 1/4" to 1 2"	25	10668	1	1	Bed slide (back) stop spring
13	15038	1	Rubber for 15035	10046	1	Bed slide 5 8"	26	11166	1	1	Slide plate
14	15039	2	Screw for 15037	10047	1	Bed slide 3 4"	27	13085	1	1	Screw for 11166
				10048	1	Bed slide 7 8"					

Remarks: The part marked \* is not used for 333R, 339R.

### THREAD TAKE UP LEVER, ARM SHAFT, TIMING BELT

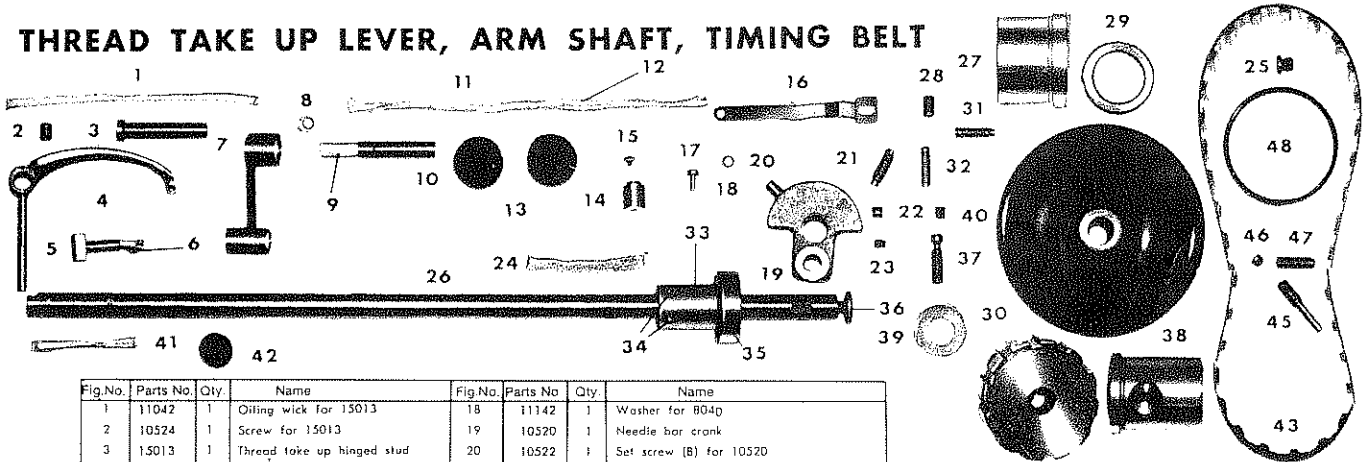

Fig.No.	Parts No.	Qty.	Name	Fig.No.	Parts No.	Qty.	Name
1	11042	1	Oiling wick for 15013	18	11142	1	Washer for 8040
2	10524	1	Screw for 15013	19	10520	1	Needle bar crank
3	15013	1	Thread take up hinged stud	20	10522	1	Set screw (B) for 10520
4	15504	1	Thread take up lever	21	10521	1	Set screw (A) for 10520
5	15026	1	Take up lever driving stud	22	10764	1	Screw (B) for 10523
6	10728	1	Oiling wick for 15026	23	10524	1	Screw (A) for 10523
7	10528	1	Needle bar connecting link	24	15033	1	Arm shaft oil wick
8	15038	1	Oil stop for 10523	25	10506	1	Arm shaft oil stop screw
9	10726	1	Oil wick for 10523	26	15011	1	Arm shaft
10	10523	1	Needle bar connecting link stud	27	13074	1	Machine arm bearing adaptor
11	11012	1	Oil wick	28	10571	1	Screw for 13074
12	15034	1	Oil adjusting vinyl pipe	29	10568	1	Ball bearing retaining washer
13	11024	2	Arm shaft bushing oiling felt	30	15205	1	Balance wheel
14	11004	1	Oil regulator	31	10576	1	Screw (A) for 15205
15	10597	1	Screw for 11004	32	10579	1	Screw (B) for 15205
16	15086	1	Oil control spring	33	13075	1	Main shaft ball bearing adaptor sleeve
17	8040	1	Screw for 15086	34	10566	2	Screw for 13075
				35	10567	1	Arm shaft ball bearing
				36	10577	1	Balance wheel adjusting screw
				37	11154	1	Screw for 13059
				38	10562	1	Arm shaft bushing (front)
				39	10563	1	Washer for 10562
				40	10524	1	Screw for 10562
				41	10729	1	Oiling wick for 10562
				42	10725	1	Felt for 10562
				43	10621	1	Arm shaft connecting belt
				44	10569	1	Arm shaft connecting belt pulley
				45	10570	1	Belt pulley position screw
				46	10524	1	Set screw for 10570
				47	10571	1	Screw for 10569
				48	10574	2	Belt pulley spring flange

### THREAD GUIDES, TENSION, KNEE LIFTER LIFTING LEVER OLD STYLE OILING SYSTEM FOR 333, 333R, 339, 339R

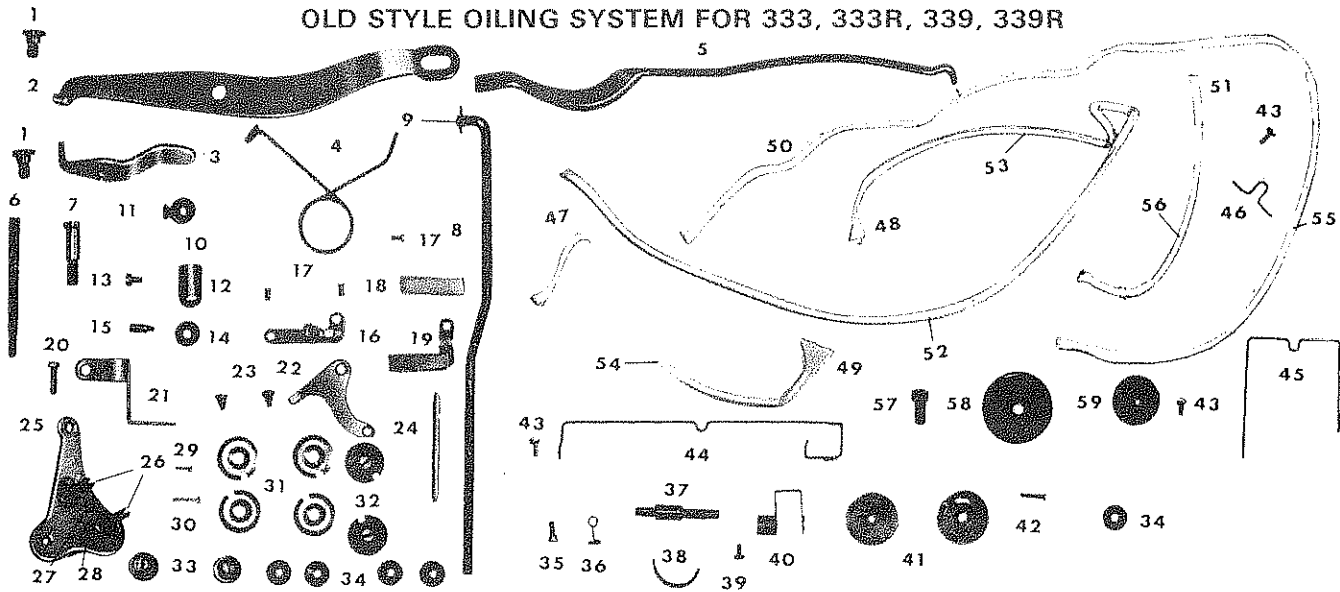
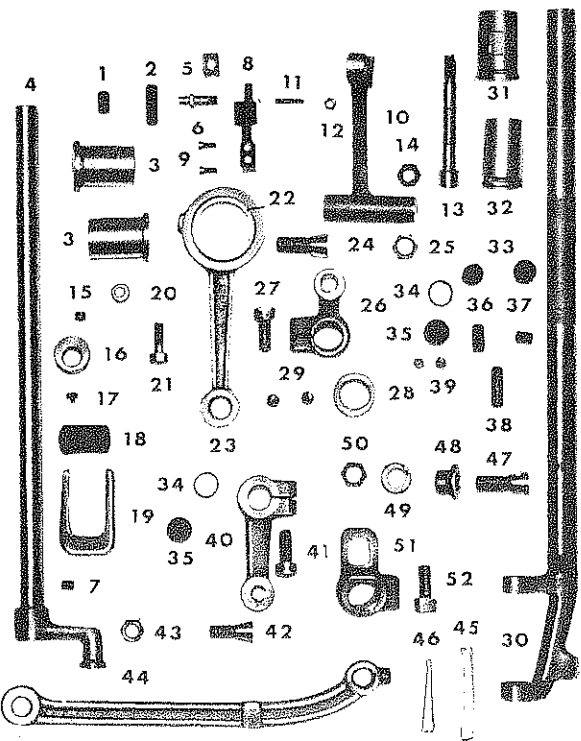

Fig.No.	Parts No.	Qty.	Name	Fig.No.	Parts No.	Qty.	Name	Fig.No.	Parts No.	Qty.	Name
1	10712	2	Knee lifter lifting lever hinge screw	21	15517	1	Thread retainer	40	10953	1	Thread controller spring
2	10710	1	Knee lifter lifting lever	22	10678	1	Tension release lever	41	10694	2	Thread controller disc
3	10711	1	Knee lifter connecting lever	23	10679	2	Tension release lever hinge screw	42	10954	1	Screw for 10694
4	13059	1	Foot lifter lifting lever spring	24	10720	1	Tension release lever rod	43	6333	3	Screw for 15508, 15083, 15084
5	10705	1	Presser bar spring (flat)	25	10956	1	Tension bracket	44	15508	1	Vinyl pipe stop (c)
6	11156	1	Presser bar spring regulating screw	26	10789	2	Tension stud	45	15084	1	Vinyl pipe stop (b)
7	10706	1	Presser bar spring support screw	27	10791	1	Tension bracket pin (short)	46	15083	1	Vinyl pipe stop (a)
8	15075	1	Knee lifter connecting lever lifting rod	28	10958	1	Tension bracket pin (long)	47	15514	1	Oiling wick No. 4
9	15076	1	Set pin for 15075	29	10957	1	Tension release plunger (short)	48	15071	1	Oiling wick No. 3
10	10714	1	Lifting rod spring collar	30	10952	1	Tension release plunger (long)	49	15515	1	Oiling wick No. 5
11	10561	1	Screw for 10714	31	10691	4	Thread disc	50	15069	1	Oiling wick No. 1
12	10717	1	Knee lifter lifting rod roller bracket	32	10692	2	Tension release washer	51	15070	1	Oiling wick No. 2
13	10561	1	Screw for 10717	33	10693	2	Tension release spring	52	15511	1	Vinyl pipe No. 4
14	10718	1	Knee lifter lifting rod roller	34	10697	5	Tension thumb nut	53	15065	1	Vinyl pipe No. 3
15	10719	1	Knee lifter lifting rod screw	35	8060	1	Screw for 10951	54	15512	1	Vinyl pipe No. 5
16	15054	1	Thread guide (upper)	36	4221	1	Oiling wick stop	55	15063	1	Vinyl pipe No. 1
17	10685	3	Thread guide set screw	37	10951	1	Thread controller stud	56	15064	1	Vinyl pipe No. 2
18	10760	1	Felt for 10759	38	10690	1	Thread controller spring stop	57	11108	1	Screw for 11105
19	10759	1	Thread guide (lower)	39	10650	1	Screw for 10690	58	11105	1	Bed oil tube clamp
20	10345	1	Screw for 10956					59	11106	1	Felt for 11105



### FEEDING MECHANISM

Fig. No.	Parts No.	Qty.	Name	Fig. No.	Parts No.	Qty.	Name
1	10525	1	Screw for front bushing	27	10754	1	Set screw for 15020
2	10571	1	Screw for rear bushing	28	10593	2	Feed driving rack shaft stop collar
3	15015	2	Rack shaft bushing	29	10764	4	Screw for 10593
4	10578	1	Needle bar rock frame rock shaft	30	10587	1	Feed driving rack shaft
5	10582	1	Needle bar rock frame slide block	31	10588	1	Feed driving rack shaft bushing (front)
6	10580	1	Needle bar rock frame slide block stud	32	10763	1	Feed driving rack shaft bushing (rear)
7	10581	1	Screw for 10580	33	11069	4	Felt for 10588, 10763
8		1	Feed dog (see attached sheet)	34	11071	2	Oil stop packing for 11069
9	10601	2	Feed dog set screw	35	11070	2	Oil stop for 11069
10	11065	1	Feed bar	36	10522	2	Screw for 10588, 10763
11	11066	1	Feed dog support screw	37	10761	1	Screw for 10588, 10763
12	11067	1	Nut for 11066	38	10571	1	Screw for 10588, 10763
13	10602	1	Feed bar hinge screw	39	11068	2	Liner for 10588, 10763
14	10636	1	Nut for 10602	40	15016	1	Needle bar rock frame rock shaft crank
15	10658	1	Screw for 10637	41	10519	1	Rack shaft crank screw
16	10637	1	Feed lifting cam	42	8014	1	Hinge screw for 10756
17	10599	1	Screw for 10596	43	8105	1	Nut for 10756
18	10596	1	Oiling felt for 10595	44	10756	1	Needle bar rock frame rock shaft crank connection
19	10595	1	Feed lifting cam fork	45	10778	1	Oiling wick for 10756
20	10599	1	Feed lifting cam fork screw washer	46	10779	1	Oiling wick stop pin
21	10598	1	Feed lifting cam fork set screw	47	10758	1	Screw for 10756
22	10773	1	Needle bearing for 15021	48	15017	1	Needle bar rock frame regulating pipe
23	15021	1	Connecting rod	49	15018	1	Washer for 15017
24	10758	1	Hinge screw for 15021	50	3036	1	Nut for 8014 (big)
25	3036	1	Nut for 10758	51	15019	1	Rack shaft crank (rear)
26	15020	1	Rack shaft crank (front)	52	10754	1	Screw for 15019

### DRIVING SHAFT, SAFETY CLUTCH

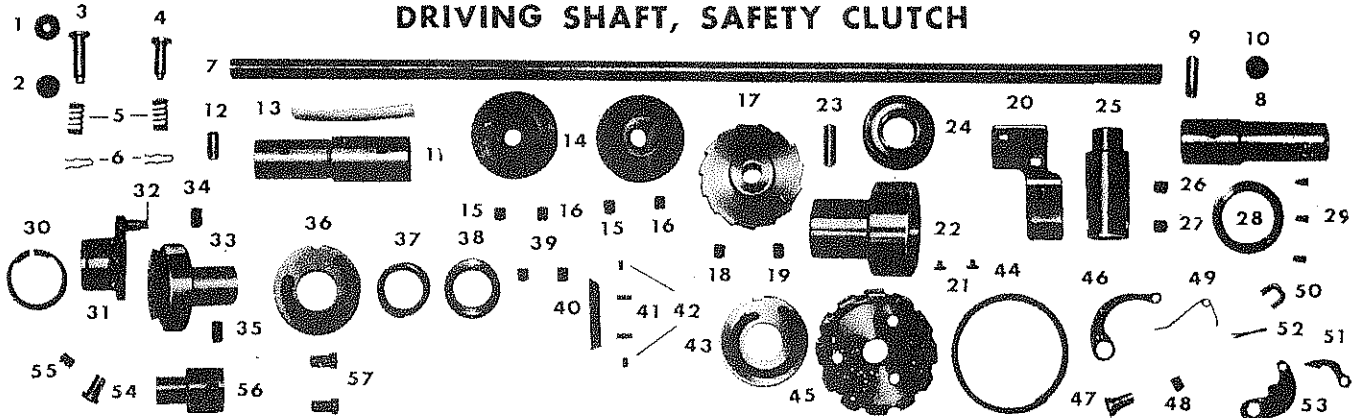

Fig.No.	Parts No.	Qty.	Name	Fig.No.	Parts No.	Qty.	Name	Fig.No.	Parts No.	Qty.	Name
1	11085	1	Driving shaft bushing oil stop screw	21	10597	2	Screw for 10822	42	10630	2	Position screw for 10631
2	11069	2	Oiling felt for 10605	22	10606	1	Lower shaft bushing (back)	43	10626	1	Feed driving eccentric adjusting disc
3	10671	1	Feed regulating stud (big)	23	10571	1	Screw for 10606	44	10574	1	Arm shaft connecting belt pulley spring flange
4	10672	1	Feed regulating stud (small)	24	10567	1	Lower shaft ball bearing	45	10941	1	Safety clutch pulley
5	10673	2	Feed regulating stud spring	25	10607	1	Lower shaft ball bearing collar	46	10615	1	Safety clutch locking lever spring
6	10674	2	Feed regulating stud spring clip	26	10658	1	Screw for 10607 (a)	47	10614	1	Hinge pin for 10615
7	12134	1	Lower shaft	27	10566	1	Screw for 10607 (b)	48	10581	1	Screw for 10614
8	10950	1	Lower shaft bushing (front)	28	10608	1	Lower shaft ball bearing retaining washer	49	10619	1	Safety clutch throw in latch spring
9	10571	1	Screw for 10950	29	10609	3	Screw for 10608	50	10618	1	Safety clutch ratchet connecting link
10	11080	1	Oiling felt for 10950	30	15023	1	Feed driving cam washer	51	10617	1	Safety clutch ratchet
11	10605	1	Lower shaft bushing	31	15022	1	Feed driving cam	52	10620	1	Safety clutch throw in latch pin
12	10522	1	Screw for 10605	32	10634	1	Feed driving eccentric pin	53	10616	1	Safety clutch locking lever
13	10729	1	Oiling wick for 10605	33	10627	1	Feed driving flange	54	10613	1	Hinge stud for 10616
14	10638	2	Hook driving gear	34	10628	1	Screw (a) for 10627	55	10581	1	Screw for 10613
15	10639	2	Set screw (a) for 10638	35	10765	1	Screw (b) for 10627	56	10611	1	Safety clutch collar
16	10766	2	Set screw (b) for 10638	36	15510	1	Feed driving eccentric adjusting disc	57	10612	2	Screw for 10611
17	10622	1	Hook driving shaft lock ratchet	37	10625	1	Feed driving eccentric adjusting disc spring				
18	10639	1	Set screw (a) for 10622	38	10623	1	Presser collar for 10625				
19	10766	1	Set screw (b) for 10622	39	10566	2	Screw for 10623				
20	10822	1	Arm shaft connecting belt timing plate	40	10631	1	Feed driving eccentric friction gib				
				41	10629	2	Screw for 10631				

Remarks: Parts marked \* are not used for 333R, 339R.  
Part marked † is used for only 333R, 339R.

### HOOK SADDLE, ROTATING HOOK, BOBBIN CASE OPENER

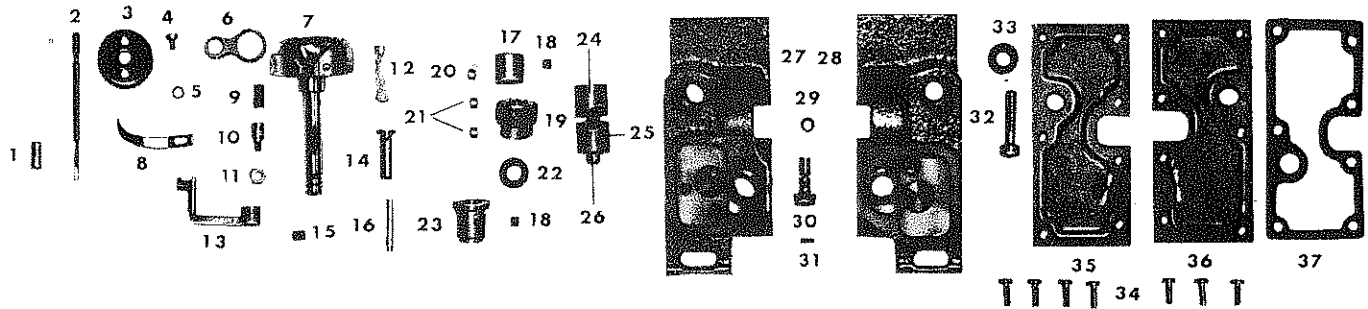

Fig.No.	Parts No.	Qty.	Name	Fig.No.	Parts No.	Qty.	Name
1	11131	2	Oil gauge guide tube	19	10657	2	Hook driving pinion (spiral)
2	15052	2	Oil gauge	20	10658	2	Screw (a) for 10657
3	15041	2	Bobbin	21	10767	4	Screw (b) for 10657
4	10650	2	Screw for 15408	22	10644	2	Washer for 15096
5	10677	2	Washer for 15048	23	15096	2	Hook saddle bushing (lower)
6	15051	2	Bobbin case lever link	24	11145	2	Pinch sleeve (upper)
7	15040	2	Rotating hook complete	25	11146	2	Pinch sleeve (lower)
8	15048	2	Bobbin case opener	26	11144	2	Hook saddle bushing set screw
9	10727	2	Felt for 10651	27	15520	1	Hook saddle (left)
10	10651	2	Bobbin case opener lever driving screw stud	28	15090	1	Hook saddle (right)
11	10652	2	Nut for 10651	29	15094	2	Ring
12	10727	2	Felt for 15049	30	15093	2	Oil regulator dial
13	15049	2	Bobbin case opener lever	31	10629	2	Screw for 15093
14	15050	2	Bobbin case opener lever hinge pin	32	10646	2	Hook saddle screw
15	10573	2	Screw for 15050	33	10647	2	Hook saddle screw washer
16	11137	2	Bobbin case opener lever hinge stud oil furnishing tube	34	6604	14	Screw for 15521, 15091
17	15095	2	Hook saddle bushing (upper)	35	15521	1	Hook saddle oil reservoir (left)
18	11176	4	Screw for 15095	36	15091	1	Hook saddle oil reservoir (right)
				37	15092	2	Gasket for hook saddle

From the library of: Diamond Needle Corp



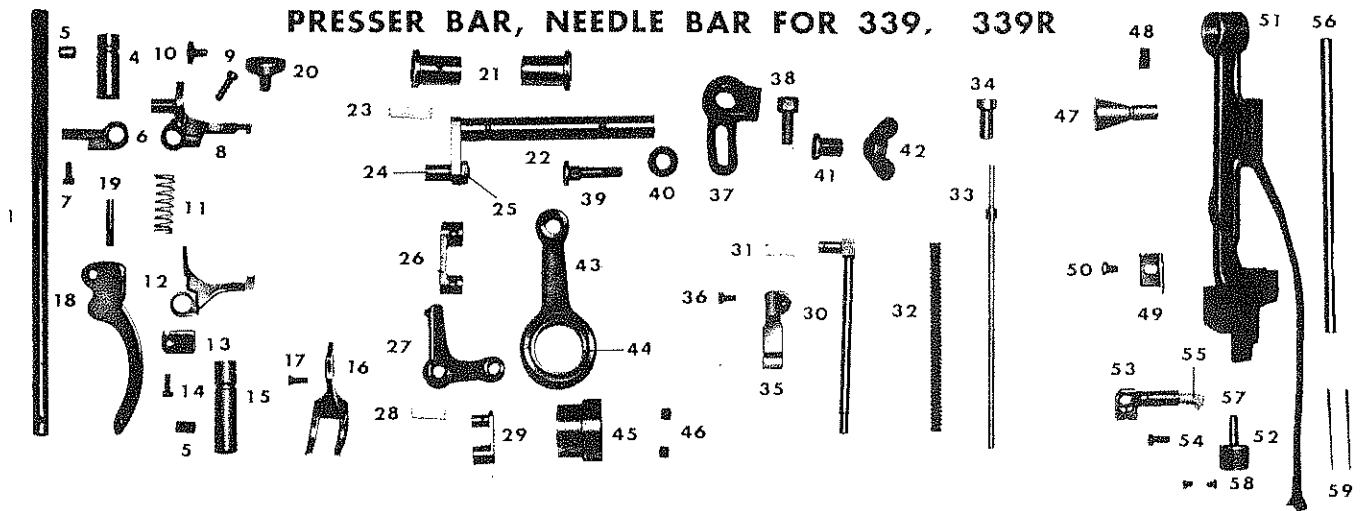
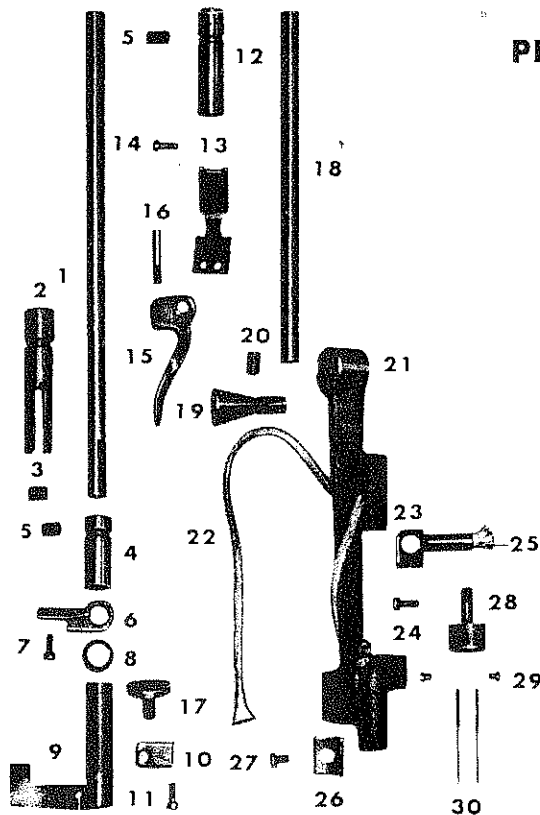

Fig.No	Parts No	Qty	Name	Fig.No	Parts No	Qty	Name	Fig.No	Parts No	Qty	Name
1	10540	1	Presser bar	21	10514	2	Lifting rock shaft bushing	41	10774	1	Lifting eccentric connection collar
2	10543	1	Presser bar position guide	22	10515	1	Lifting rock shaft	42	10776	1	Lifting eccentric connection wing nut
3	10761	1	Screw for 10543	23	10728	1	Oiling wick 15053	43	10772	1	Lifting eccentric connection
4	10538	1	Presser bar bushing (upper)	24	15053	1	Screw for 10515	44	10773	1	Needle bearing for 10772
5	10761	2	Set screw for 10538	25	10517	1	Nut for 15053	45	10771	1	Lifting eccentric
6	10541	1	Presser bar position guide bracket	26	10557	1	Lifting bell crank link	46	10566	2	Screw for 10771
7	10662	1	Set screw for 10541	27	10558	1	Lifting bell crank	47	10537	1	Needle bar rock frame hinged stud
8	10544	1	Presser bar lifting bracket	28	10728	1	Oiling wick for 10557	48	10525	1	Screw for 10537
9	10545	1	Screw for 10544	29	10556	1	Vibrating presser bar connecting link	49	10560	1	Needle bar rock frame position bracket
10	10559	1	Lifting bell crank set screw	30	10555	1	Vibrating presser bar	50	10561	1	Set screw for 10560
11	10547	1	Tension release spring	31	10728	1	Oiling wick for 10555	51	15545	1	Needle bar rock frame
12	10346	1	Tension release slide	32	10554	1	Vibrating presser bar extension spring	52	15031	1	Oiling wick for 15545
13	10549	1	Presser bar spring bracket	33	10553	1	Vibrating presser bar extension	53	10531	1	Needle bar connecting stud
14	10532	1	Screw for 10549	34	15060	1	Screw for 10553	54	10532	1	Screw for 10531
15	10539	1	Presser bar bushing (lower)	35	10556	1	Vibrating presser foot	55	10726	1	Oiling wick for 10531
16	10664	1	Lifting presser foot (see attached sheet)	36	10662	1	Vibrating presser foot pinch screw	56	10955	1	Needle bar
17	13055	1	Screw for lifting presser foot	37	10751	1	Lifting eccentric connecting crank	57	10535	2	Needle clamp
18	13055	1	Presser bar lifter	38	10754	1	Screw for 10751	58	6332	2	Needle set screw
19	10660	1	Presser bar lifter hinge screw	39	10775	1	Hinge screw	59			Needle
20	10548	1	Presser bar lifting bracket guide screw	40	10703	1	Washer for 10775				



### PRESSER BAR, NEEDLE BAR FOR 333, 333R

Fig.No	Parts No	Qty	Name
1	10540	1	Presser bar
2	10543	1	Presser bar position guide
3	10761	1	Set screw for 10543
4	10538	1	Presser bar bushing (upper)
5	10761	2	Screw for presser bar bushing
6	10541	1	Presser bar position guide bracket
7	10662	1	Set screw for 10541
8	10858	1	Washer for 10857
9	10857	1	Presser bar lifting bracket
10	10549	1	Presser bar spring bracket
11	10532	1	Screw for 10549
12	10539	1	Presser bushing (lower)
13		1	Presser foot (see attached sheet)
14	10664	1	Presser foot set screw
15	10659	1	Presser bar lifter
16	10660	1	Presser bar lifter hinge screw
17	10548	1	Presser bar lifting bracket guide screw
18	10992	1	Needle bar
19	10537	1	Needle bar rock frame hinged stud
20	10525	1	Screw for 10537
21	15304	1	Needle bar rock frame
22	15031	1	Oiling wick for 15304
23	10856	1	Needle bar connecting stud
24	10532	1	Screw for 10856
25	10726	1	Oiling wick for 10856
26	10560	1	Needle bar rock frame position bracket
27	10561	1	Screw for 10560
28		1	Needle clamp (see attached sheet)
29	10535	2	Needle set screw
30	6332	2	Needle

### GAUGE PARTS FOR 339, 339R

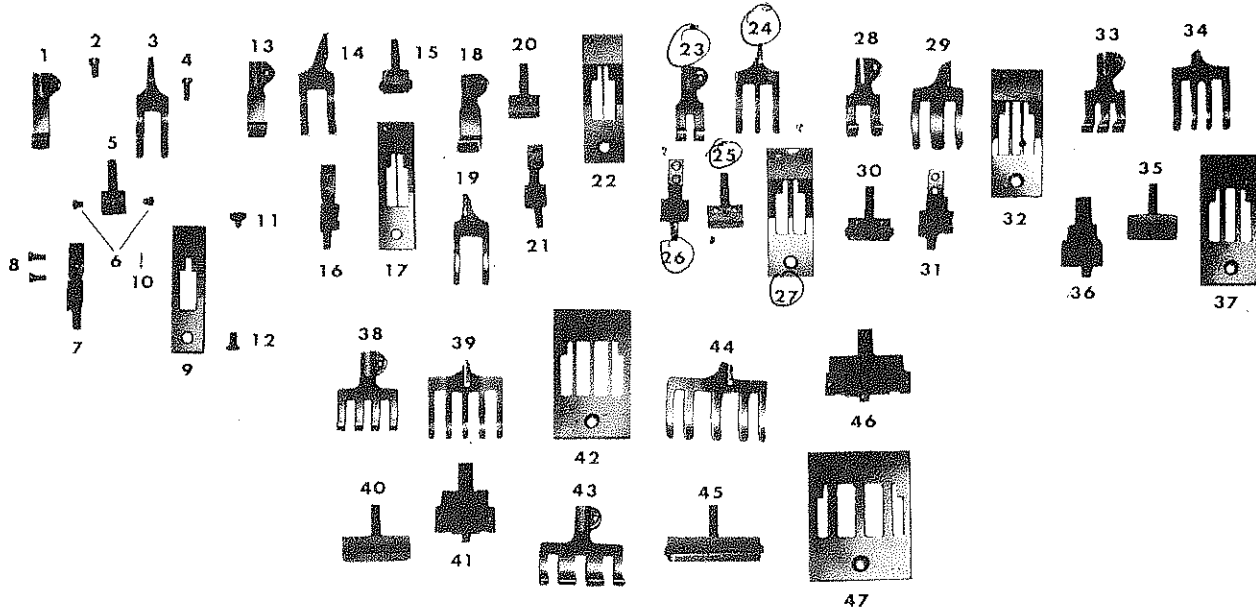

Fig.No.	Parts No.	Qty.	Name	Fig.No.	Parts No.	Qty.	Name
1	10282	1	Vibrating presser foot	27	11226	1	Needle plate 3/8"
2	10662	1	Set screw for 10282		10288	1	Vibrating presser foot 7/16"
3	10182	1	Lifting presser foot		10188	1	Lifting presser foot 7/16"
4	10664	1	Lifting presser foot set screw		10128	1	Needle clamp 7/16"
5	10122	1	Needle clamp		10268	1	Feed dog 7/16"
6	10535	2	Needle set screw		10228	1	Needle plate
7	11232	1	Feed dog	28	10289	1	Vibrating presser foot 1.2"
8	10601	2	Feed dog set screw	29	10189	1	Lifting presser foot 1/2"
9	11222	1	Needle plate	30	10129	1	Needle clamp 1/2"
10	11163	1	Pin for 11222	31	10269	1	Feed dog 1/2"
11	11162	1	Needle plate position screw	32	10229	1	Needle plate 1-2"
12	6031	1	Screw for 11222		10290	1	Vibrating presser foot 9/16"
			Vibrating presser foot 1/16"		10190	1	Lifting presser foot 9/16"
			Lifting presser foot 1/16"		10130	1	Needle clamp 9/16"
			Needle clamp 1/16"		10270	1	Feed dog 9/16"
			Feed dog 1/16"		10230	1	Needle plate 9/16"
			Needle plate 1/16"	33	10291	1	Vibrating presser foot 5/8"
			Vibrating presser foot 3/32"	34	10191	1	Lifting presser foot 5/8"
			Lifting presser foot 3/32"	35	10131	1	Needle clamp 5/8"
			Needle clamp 3/32"	36	10271	1	Feed dog 5/8"
			Feed dog 3/32"	37	10231	1	Needle plate 5/8"
			Needle plate 3/32"		10292	1	Vibrating presser foot 3/4"
13	10283	1	Vibrating presser foot 3/16"		10192	1	Lifting presser foot 3/4"
14	10183	1	Lifting presser foot 3/16"		10132	1	Needle clamp 3/4"
15	10123	1	Needle clamp 3/16"		10272	1	Feed dog 3/4"
16	11233	1	Feed dog 3/16"		10232	1	Needle plate 3/4"
17	11223	1	Needle plate 3/16"		10293	1	Vibrating presser foot 7/8"
	10284	1	Vibrating presser foot 7/32"		10193	1	Lifting presser foot 7/8"
	10184	1	Lifting presser foot 7/32"		10133	1	Needle clamp 7/8"
	10124	1	Needle clamp 7/32"		10273	1	Feed dog 7/8"
	10264	1	Feed dog 7/32"		10233	1	Needle plate 7/8"
	10224	1	Needle plate 7/32"	38	10294	1	Vibrating presser foot 1"
18	10285	1	Vibrating presser foot 1/4"	39	10194	1	Lifting presser foot 1"
19	10185	1	Lifting presser foot 1/4"	40	10134	1	Needle clamp 1"
20	10125	1	Needle clamp 1/4"	41	10274	1	Feed dog 1"
21	11234	1	Feed dog 1/4"	42	10234	1	Needle plate 1"
22	11224	1	Needle plate 1/4"		10295	1	Vibrating presser foot 1 1/4"
	10286	1	Vibrating presser foot 5/16"		10195	1	Lifting presser foot 1 1/4"
	10186	1	Lifting presser foot 5/16"		10135	1	Needle clamp 1 1/4"
	10126	1	Needle clamp 5/16"		10275	1	Feed dog 1 1/4"
	11235	1	Feed dog 5/16"		10235	1	Needle plate 1 1/4"
	11225	1	Needle plate 5/16"	43	10296	1	Vibrating presser foot 1 1/2"
23	10287	1	Vibrating presser foot 3/8"	44	10196	1	Lifting presser foot 1 1/2"
24	10187	1	Lifting presser foot 3/8"	45	10136	1	Needle clamp 1 1/2"
25	10127	1	Needle clamp 3/8"	46	10276	1	Feed dog 1 1/2"
26	11236	1	Feed dog 3/8"	47	10236	1	Needle plate 1 1/2"

### REVERSE STITCH MECHANISM FOR 333R, 339R — OLD STYLE

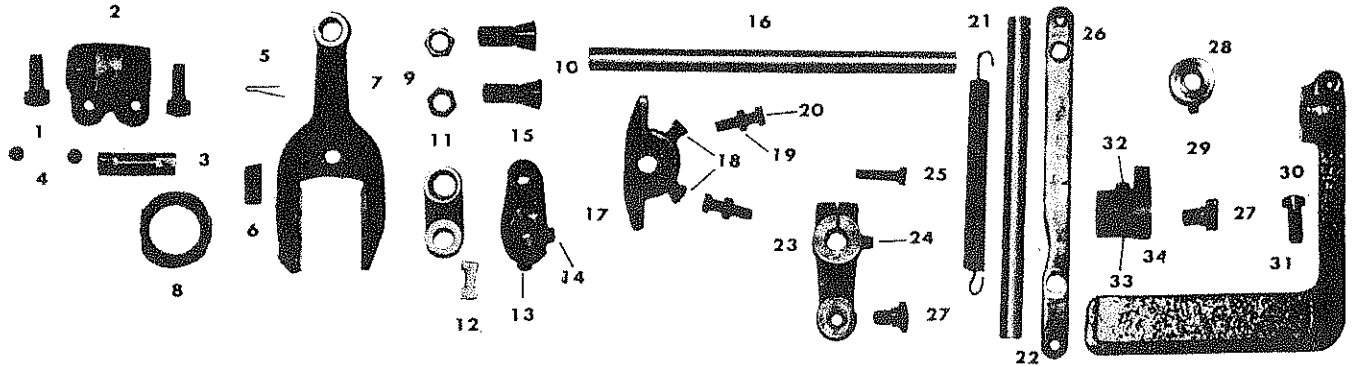

Fig No.	Parts No.	Qty.	Name	Fig No.	Parts No.	Qty.	Name	Fig No.	Parts No.	Qty.	Name
1	10519	2	Screw for 10820	13	10828	1	Screw for 10838 (B)	25	10812	1	Clamp screw for 10842
2	10820	1	Feed rock shaft bell crank	14	10827	1	Screw for 10838 (A)	26	10841	1	Bell crank connecting rod
3	10821	1	Pin for 10820	15	10838	1	Feed reverse shaft bell crank	27	10712	2	Screw for 10841
4	10828	2	Screw for 10821	16	10403	1	Feed reverse shaft	28	10802	1	Fulcrum shaft collar
5	10829	1	Pin for 10818	17	10811	1	Feed reverse shaft stop	29	8009	1	Screw for 10802
6	10818	1	Felt for 10840	18	10812	2	Screw for 10811	30	10845	1	Screw for 10844
7	10840	1	Feed reverse fork	19	10813	2	Nut for 10812	31	10844	1	Reverse feed lever
8	10819	1	Feed reverse fork collar	20	10812	2	Feed reverse shaft stop regulating screw	32	10828	1	Screw for 10843 (B)
9	3036	2	Nut for 10758	21	10806	1	Reverse lever return spring	33	10827	1	Screw for 10843 (A)
10	10758	2	Hinge screw for 10839	22	15208	1	Fulcrum shaft	34	10843	1	Feed reverse shaft bell crank
11	10839	1	Feed reverse fork connecting link	23	10842	1	Fulcrum shaft bell crank				
12	10837	1	Felt for 10839	24	8087	1	Position screw for 10843				

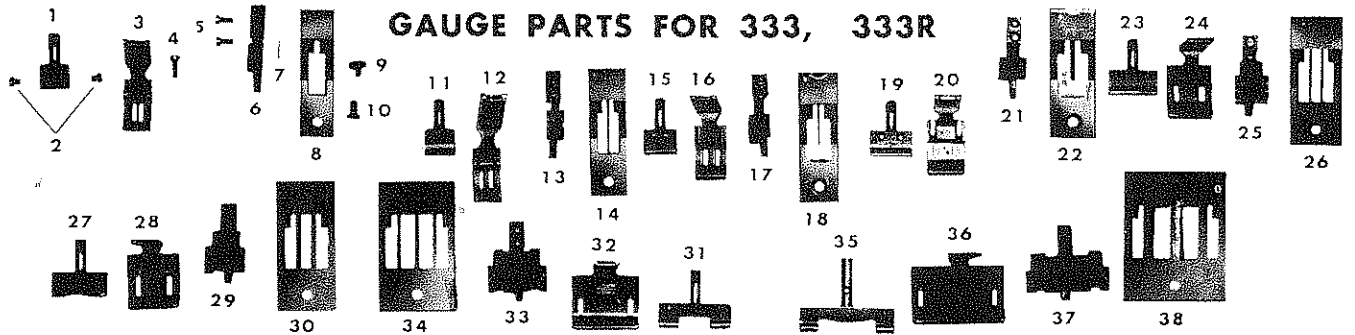
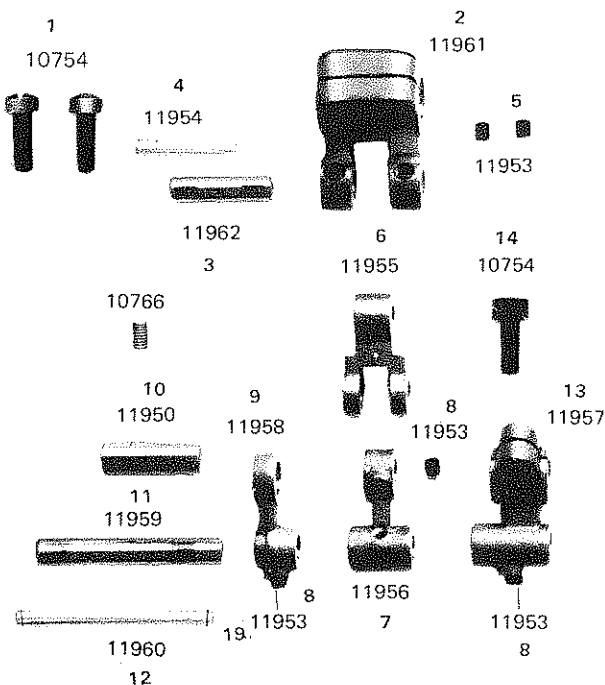
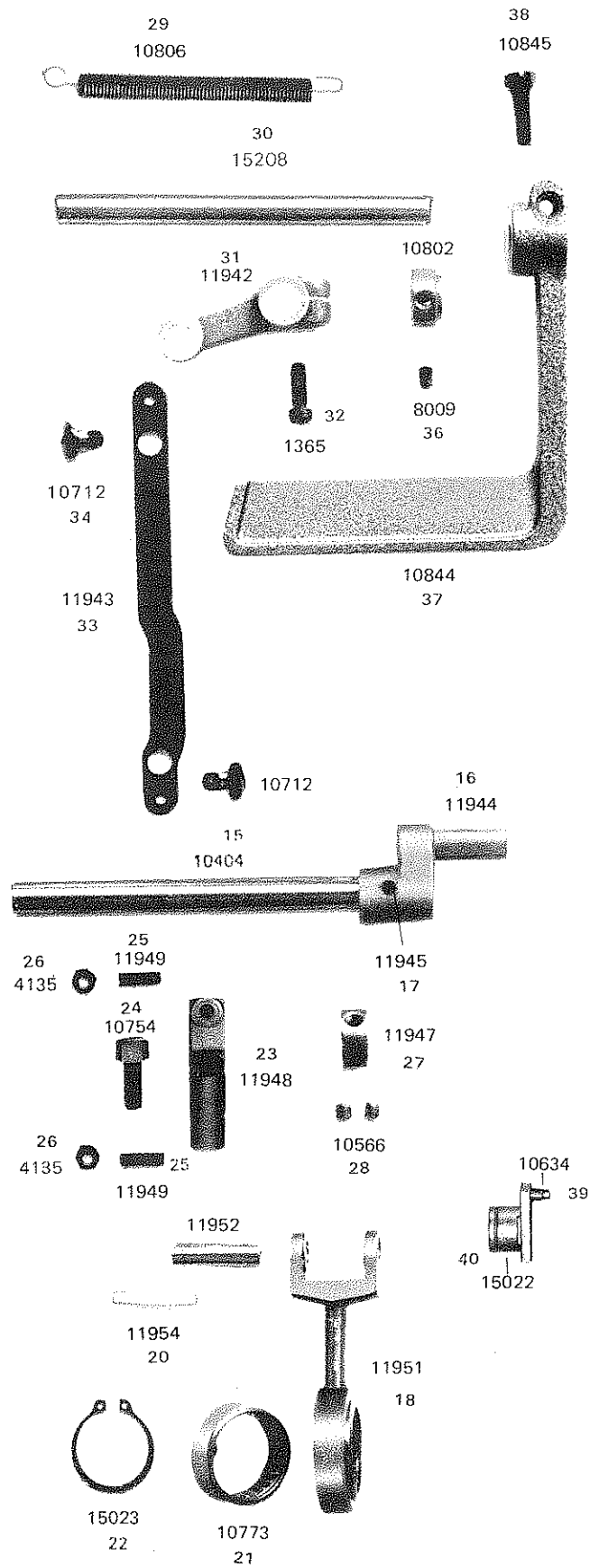

Fig No.	Parts No.	Qty.	Name	Fig No.	Parts No.	Qty.	Name	Fig No.	Parts No.	Qty.	Name
1	10102	1	Needle clamp 1/8"	15	10224	1	Needle plate 7/32"	27	10111	1	Needle clamp 5/8"
2	10535	2	Needle set screw	16	11214	1	Presser foot 1/4"	28	10171	1	Presser foot 5/8"
3	11212	1	Presser foot 1/8"	17	11234	1	Feed dog 1/4"	29	10271	1	Feed dog 5/8"
4	10664	1	Presser foot set screw	18	11224	1	Needle plate 1/4"	30	10231	1	Needle plate 5/8"
5	1060	2	Feed dog set screw	19	10106	1	Needle clamp 5/16"	10112	1	Needle clamp 3/4"	
6	11232	1	Feed dog 1/8"	20	11215	1	Presser foot 5/16"	10172	1	Presser foot 3/4"	
7	11163	1	Pin for needle plate	21	11235	1	Feed dog 5/16"	10272	1	Feed dog 3/4"	
8	11222	1	Needle plate 1/8"	22	11225	1	Needle plate 5/16"	10232	1	Needle plate 3/4"	
9	11162	1	Needle plate position screw	19	10107	1	Needle clamp 3/8"	10113	1	Needle clamp 7/8"	
10	6031	1	Needle plate set screw	20	11216	1	Presser foot 3/8"	10173	1	Presser foot 7/8"	
	12065	1	Needle clamp 1/16"	21	11236	1	Feed dog 3/8"	10273	1	Feed dog 7/8"	
	11210	1	Presser foot 1/16"	22	11226	1	Needle plate 3/8"	10233	1	Needle plate 7/8"	
	11230	1	Feed dog 1/16"		10108	1	Needle Clamp 7/16"	31	10114	1	Needle clamp 1"
	11220	1	Needle plate 1/16"		10168	1	Presser foot 7/16"	32	10174	1	Presser foot 1"
	12065	1	Needle clamp 3/32"		10268	1	Feed dog 7/16"	33	10274	1	Feed dog 1"
	11211	1	Presser foot 3/32"		10228	1	Needle plate 7/16"	34	10234	1	Needle plate 1"
	11231	1	Feed dog 3/32"	23	10109	1	Needle clamp 1/2"	10115	1	Needle clamp 1 1/4"	
	11221	1	Needle plate 3/32"	24	10169	1	Presser foot 1/2"	10175	1	Presser foot 1 1/4"	
11	10103	1	Needle clamp 3/16"	25	10269	1	Feed dog 1/2"	10275	1	Feed dog 1 1/4"	
12	11213	1	Presser foot 3/16"	26	10229	1	Needle plate 1/2"	10235	1	Needle plate 1 1/2"	
13	11233	1	Feed dog 3/16"		10110	1	Needle clamp 9/16"	35	10116	1	Needle clamp 1 1/2"
14	11223	1	Needle plate 3/16"		10170	1	Presser foot 9/16"	36	10176	1	Presser foot 1 1/2"
	10104	1	Needle clamp 7/32"		10270	1	Feed dog 9/16"	37	10276	1	Feed dog 1 1/2"
	10164	1	Presser foot 7/32"		10230	1	Needle plate 9/16"	38	10236	1	Needle plate 1 1/2"
	10264	1	Feed dog 7/32"								

### NEW REVERSE STITCH MECHANISM FOR 333RB-1, 333RBL-1, 339RB-1, 339RBL-1

Fig. No.	Parts No.	Qty	Name
1	10754	2	Screw for 11961
2	11961	1	Feed rock shaft bell crank
3	11962	1	Pin for 11961
4	11954	1	Oiling wick for 11962
5	11953	2	Screw for 11962
6	11955	1	Feed reverse forked link
7	11956	1	Feed reverse connecting link
8	11953	3	Screw for 11952, 11959
9	11958	1	Change-over crank (left)
10	11950	1	Feed reverse pin
11	11959	1	Change-over crank pin
12	11960	1	Oiling wick for 11959
13	11957	1	Change-over crank (right)
14	10754	1	Screw for 11957
15	10404	1	Feed reverse shaft
16	11944	1	Feed reverse shaft bell crank
17	11945	1	Pin for 11944
18	11951	1	Connecting rod
19	11952	1	Connecting rod wrist pin
20	11954	1	Oiling wick for 11952
21	10773	1	Needle bearing for 11951
22	15023	1	Feed driving cam snap ring
23	11948	1	Feed reverse shaft stop
24	10754	1	Screw for 11948
25	11949	2	Screw for 11948
26	4135	2	Nut for 10949
27	11947	1	Fulcrum shaft collar
28	10566	2	Screw for 11947
29	10806	1	Reverse lever return spring
30	15208	1	Fulcrum shaft
31	11942	1	Fulcrum shaft bell crank
32	1365	1	Clamp screw for 11942
33	11943	1	Bell crank connecting rod
34	10712	2	Screw for 10943
35	10802	1	Fulcrum shaft collar
36	8009	2	Screw for 10802
37	10844	1	Reverse feed lever
38	10845	1	Screw for 10844
39	10634	1	Pin for 15022
40	15022	1	Feed Driving Eccentric





## NEW STYLE OIL WICK FOR BED

Fig. No.	Parts No.	Qty	Name
1	15069		Oiling wick - #1
2	15063		Vinyl pipe - #1
3	15070		Oiling wick - #2
4	15064		Vinyl pipe - #2
5	15097		Vinyl pipe stop
6	6333		Screw for 15097-15088-15508-15087
7	15509		Vinyl pipe - #3
8	15513		Oiling wick - #3
9	15088		Vinyl pipe stop
10	15067		Vinyl pipe - #4
11	15073		Oiling wick - #4
12	15511		Vinyl pipe - #5
13	15514		Oiling wick - #5
14	15508		Vinyl pipe stop
15	15087		Vinyl pipe stop
16	11106		Felt
17	11108		Screw for 15077
18	15077		Bed oil clamp

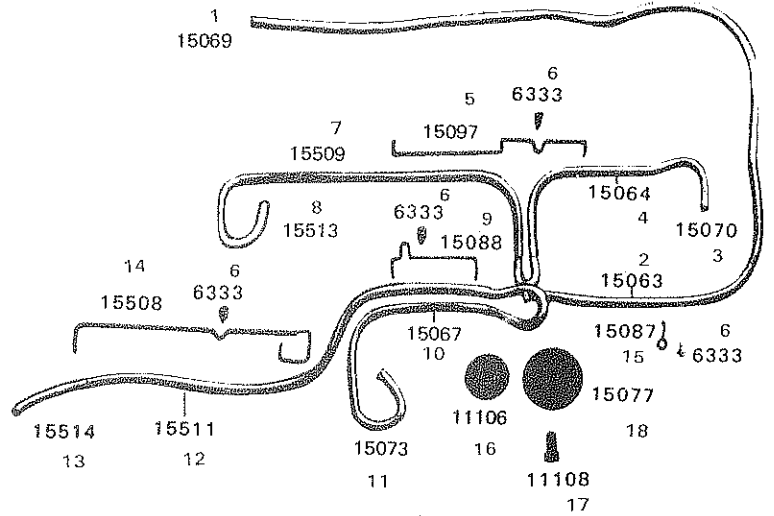

## ACCESSORIES

Fig. No.	Parts No.	Qty	Name
1	10735	1	Knee Lifter Complete
2	6052	3	Nail
4	8125	1	Oiler
5	15082	1	Oil Bottle
6	15081	6	Screw for 15080
7	15080	1	Oil pan
8	11171	2	Bed hinge connection base
9	6052	4	Screw for 11171
10	11170	4	Bed hinge connection set screw
11	11169	2	Bed hinge connection
12	15101	1	Bobbin winder complete
13	11197	1	Cotton stand complete
14	15099	1	Belt Guard
15	11162	2	Screw for 15099
16	12418	1	Screw for 15098
17	10598	1	Belt guard
18	11142	1	Washer
19	10650	1	Screw for 15098

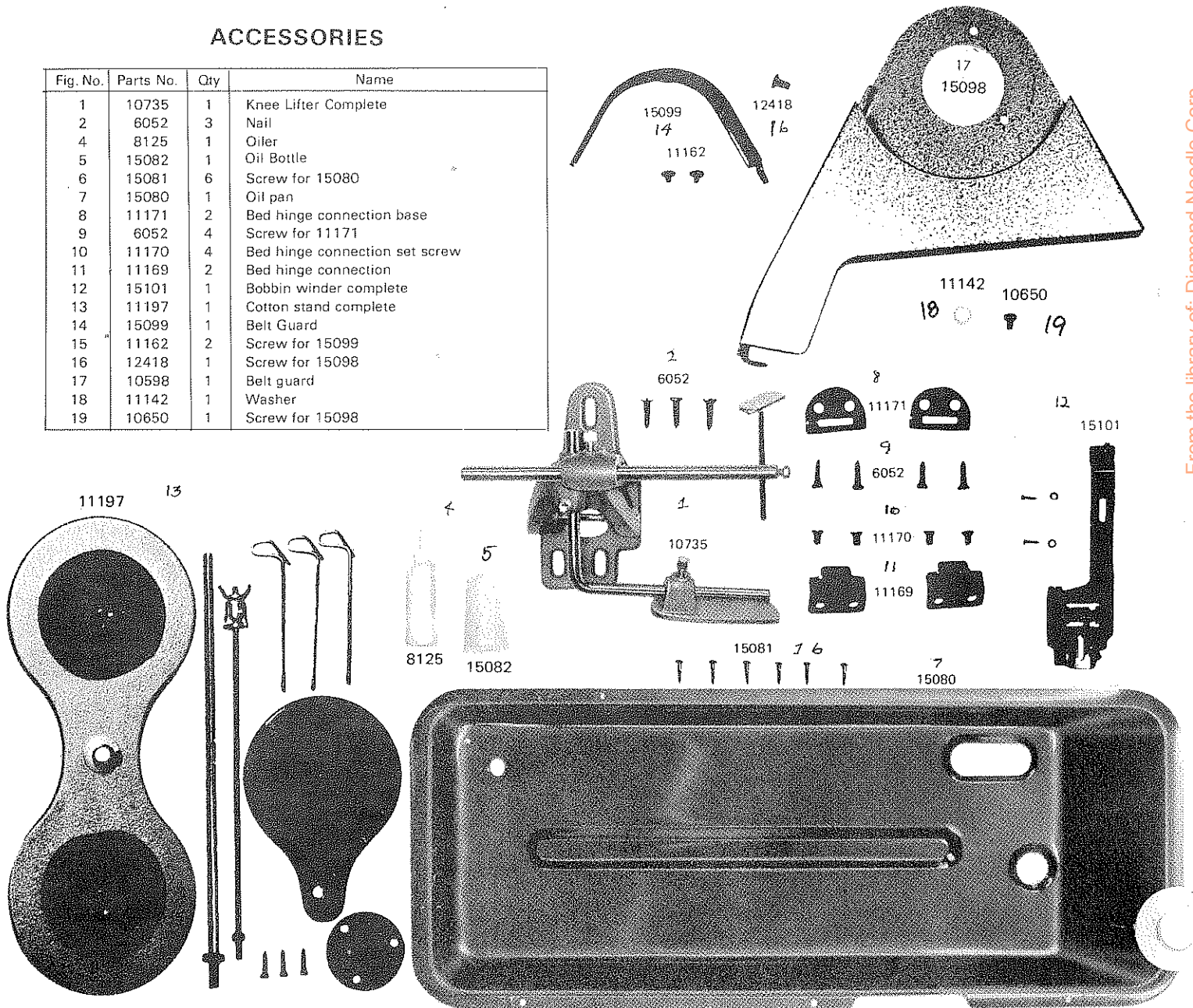

NOTE: ALL LONG ARM MACHINES REQUIRE SPECIAL ORDER.  
FOR DRIP PAN-SHAFTS AND ALL OTHER EXTENDED PARTS PLEASE SPECIFY WHEN ORDERING.